

12 Channels Constant Voltage DMX512 & RDM Decoder

- Comply with the DMX512 standard protocols.
- Digital numeric display, set DMX decode start address by buttons.
- RDM function can realize intercommunication between DMX master and decoder. For example, DMX decoder address can be set by DMX master console.
- 16bit (65536 levels) /8bit (256 levels) grey level selectable.
- PWM frequency 500/1000/2000/4000/8000/16000/32000Hz selectable.
- Logarithmic or linear dimming curve selectable.
- Stand-alone 12-channel RGB mode and 12-channel dimmer mode selectable, which be controlled by buttons with built-in programs, instead of DMX signal.



FC CE RoHS

Technical Parameters

| Input and Output | Environment | Safety and EMC |
|---------------------------------------------|------------------------------------------|-------------------------------------------------------------------------------------------------------------------|
| Input voltage: 12-24VDC | Operation temperature: Ta: -30°C ~ +55°C | EMC standard: EN IEC 55015:2019+A11:2020, EN 61547:2009, EN IEC 61000-3-2:2019+A1:2021, EN 61000-3-3:2013+A1:2019 |
| Input current: 60.5A | Case temperature (Max.): Tc: +85°C | Safety standard: EN 61347-1:2015+A1:2021, EN 61347-2-13:2014+A1:2017 |
| Output voltage: 12 x (12-24)VDC | Warranty and Protection | Certification: CE |
| Output current: 12CH, 5A/CH, Total Max. 60A | Warranty: 5 years | Package |
| Output power: 12 x (60-120)W | Protection: Reverse Polarity | Size: L165 x W98 x H72mm |
| Output type: Constant voltage | | Gross weight: 0.30kg |

Mechanical Structures and Installations

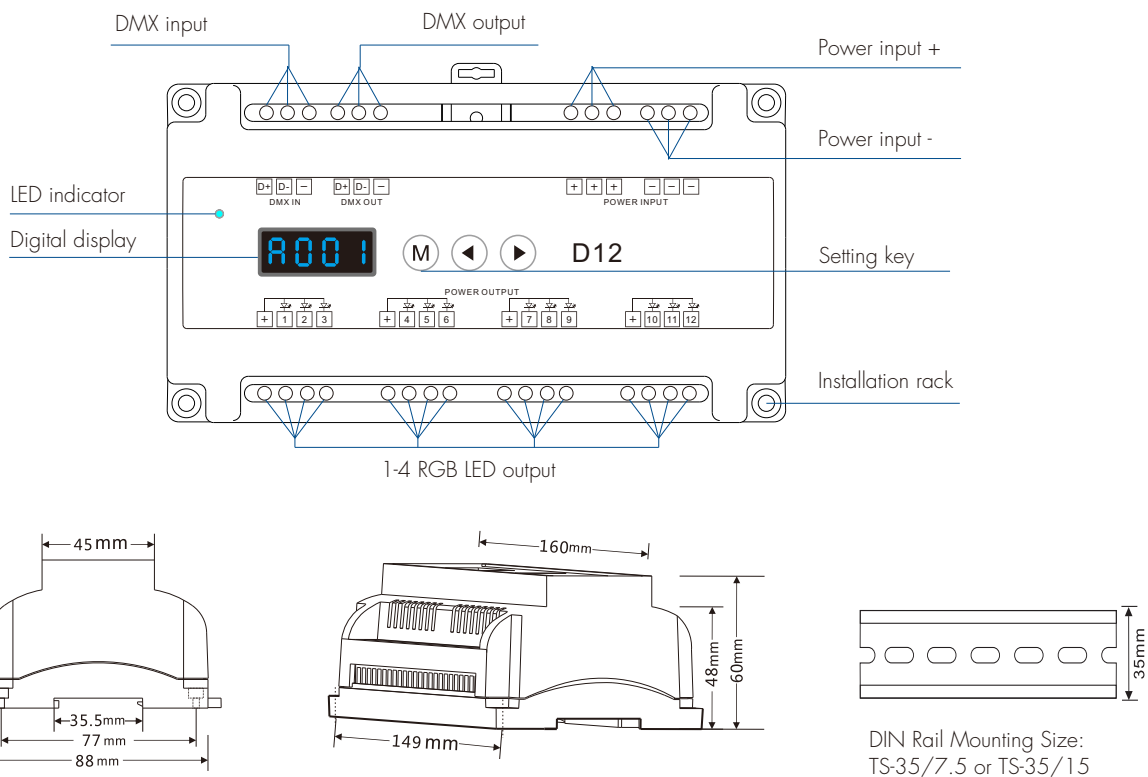

Wiring Diagram

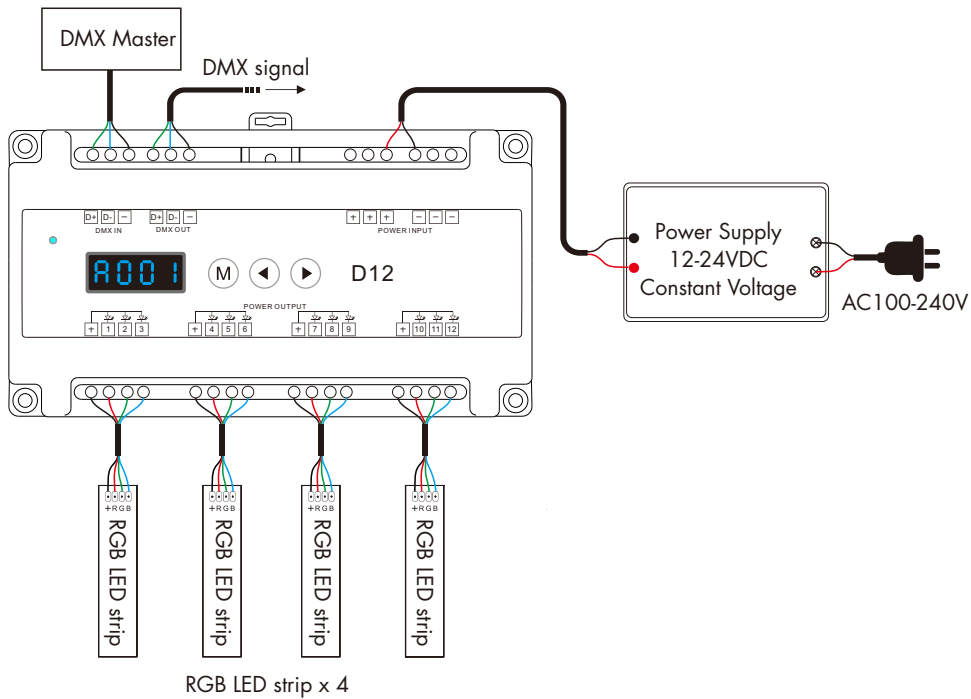

- Note:**
1. An DMX signal amplifier is needed if more than 32 decoders are connected, or use overlong signal line, signal amplification should not be more than 5 times continuously.
 2. If the recoil effect occurs because of longer signal line or bad line quality, please try to connect 0.25W 90-120Ω terminal resistor at the end of each line.

Operation

System parameter setting

- Long press M and ◀ key for 2s, prepare for setup system parameter: decode mode, grey level, output PWM frequency, output brightness curve, default output level, automatic blank screen. Short press M key to switch six item.
- Decode mode: short press ◀ or ▶ key to switch 1-channel decode("d01"), 3-channel decode("d03"), 6-channel decode("d06") or 12-channel decode("d12"). When set as 1 channel decode, the decoder occupy only 1 DMX address, and 12 channels output the same brightness of this DMX address.
- Grey level: short press ◀ or ▶ key to switch 8bit("b08") or 16 bit("b16"). choose 16 bit if the DMX master support 16 bit.
- Output PWM frequency: short press ◀ or ▶ key to switch 500Hz("F005"), 1000Hz("F010"), 2000Hz("F020"), 4000Hz("F040"), 8000Hz("F080"), 16000Hz("F160") or 32000Hz("F320"). Higher PWM frequency, will cause lower output current, higher power noise, but more suitable for camera(No flickers for video). When PWM frequency > 8000Hz, it is necessary to reduce the output current per channel (12x3A@12-24V at 16000Hz; 12x2A@12-24V at 32000Hz).
- Output brightness curve: short press ◀ or ▶ key to switch linear curve("C-L") or logarithmic curve("C-E").
- Default output level: set output level when no DMX input signal. short press ◀ or ▶ key to switch maintain DMX output("d-") or output default level ("d00" to "dFF", 0-100%), long press ◀ or ▶ key to change output default level.
- Automatic blank screen: short press ◀ or ▶ key to switch enable ("bon") or disable("boff") automatic blank screen.
- Long press M key for 2s or timeout 10s, quit system parameter setting.

DMX mode

- Short press M key, when display A001~A512, enter DMX mode.
- Press ◀ or ▶ key to change DMX decode start address(001~512), long press for fast adjustment.
- If there is a DMX signal input, will enter DMX mode automatically.
- DMX Dimming: Each D12 DMX decoder occupy 12 DMX addresses when connecting the DMX console. For example, the defaulted start address is 1, their corresponding relationship in the form:



| DMX Console | DMX Decoder Output |
|-------------|---------------------------|
| CH1 0-255 | CH1 PWM 0-100% (LED 1#R) |
| CH2 0-255 | CH2 PWM 0-100% (LED 1#G) |
| CH3 0-255 | CH3 PWM 0-100% (LED 1#B) |
| ⋮ | ⋮ |
| CH12 0-255 | CH12 PWM 0-100% (LED 4#B) |

Stand-alone RGB mode

- Short press M key, when display P-1~P-4, enter stand-alone RGB mode.
- Press ◀ or ▶ key to change dynamic mode number(P-1~P-4).
- Each mode can adjust speed and brightness. Long press M key for 2s, prepare for setup mode speed, brightness. Short press M key to switch two item. Press ◀ or ▶ key to setup value of each item. Mode speed: 1-10 level speed(SP-1, SP-9, SP-F). Mode brightness: 1-10 level brightness(br-1, br-9, br-F). Long press M key for 2s or timeout 10s, quit setting.
- Enter stand-alone RGB mode only when DMX signal is disconnected or lost.



Stand-alone RGB mode
(P--1~P--4)



Speed
(8 level)

Brightness
(10 level, 100%)

RGB change mode list

| No. | Name |
|-----|---------------------------------------------------------|
| P-1 | White forward jump chase |
| P-2 | White forward smooth float |
| P-3 | Red,green,blue,white forward jump chase |
| P-4 | Red,yellow, green,cyan,blue,purple forward smooth float |

Stand-alone dimmer mode

- Short press M key, when display L-1~L-8, enter stand-alone dimmer mode.
- Press ◀ or ▶ key to change dimmer mode number(L-1~L-8).
- Each dimmer mode can adjust each channel brightness independently.
Long press M key for 2s, prepare for setup 12 channels brightness.
Short press M key to switch 12 channel(0100~01FF, 0200~02FF, 0300~03FF, ... , 1200~12FF).
Press ◀ or ▶ key to setup brightness value of each channel.
Long press M key for 2s or timeout 10s, quit setting.
- Enter stand-alone dimmer mode only when DMX signal is disconnected or lost.



Stand-alone dimmer mode
(L-1~L-8)

Restore factory default parameter

- Long press ◀ and ▶ key for 2s, restore factory default parameter, display"RES".
- Factory default parameter: DMX decode mode, DMX decode start address is 1, 12 channels decode, 8 bit grey level, 2000Hz PWM frequency output, logarithmic brightness curve, output 100% level when no DMX input, RGB mode number is 1, dimmer mode number is 1, disable automatic blank screen.

Dimming Curve Setting

Linear dimming curve

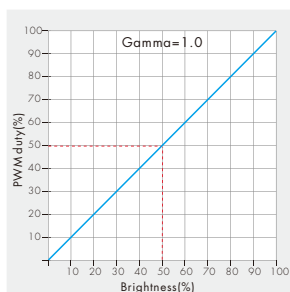

Logarithmic dimming curve

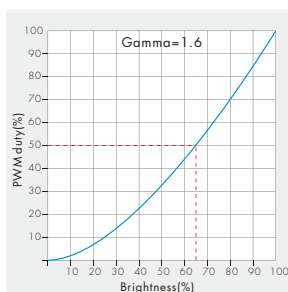

Malfunctions Analysis & Troubleshooting

| Malfunctions | Causes | Troubleshooting |
|-----------------------------------------------------------|------------------------------------------------------------------------------------------------------------------------------------------------------------|-----------------------------------------------------------------------------------------------------------------------|
| No light | 1. No power. 2. Wrong connection or insecure. | 1. Check the power. 2. Check the connection. |
| Wrong color | 1. Wrong connection of R/G/B wires. 2. DMX decode address error. | 1.Reconnect R/G/B wires. 2. Set correct decode address. |
| Uneven intensity between front and rear,with voltage drop | 1. Output cable is too long. 2. Wire diameter is too small. 3. Overload beyond power supply capability. 4. Overload beyond controller capability. | 1. Reduce cable or loop supply. 2. Change wider wire. 3. Replace higher power supply. 4. Add power repeater. |