

3 Channel Constant Voltage DMX512 & RDM Decoder

D3

Feature

- Comply with the DMX512 standard protocols.
- Digital numeric display, set DMX address by buttons.
- RDM function can realize intercommunication between DMX master and decoder. For example, DMX decoder address can be set by DMX master console.
- PWM frequency 2000/500Hz selectable.
- Logarithmic or linear dimming curve selectable.
- Stand-alone RGB mode and 3 channel dimmer mode selectable.

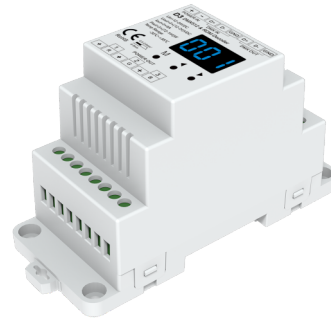

Technical parameter

Input and Output

Input voltage	12-24VDC
Input current	18.5A
Output voltage	3 x (12-24)VDC
Output current	3CH,6A/CH
Output power	3 x (72-144)W
Output type	Constant voltage

Environment

Operation temperature	Ta: -30°C~+55°C
Case temperature (Max.)	Tc: +85°C
IP rating	IP20

Safety and EMC

EMC standard (EMC)	EN55032:2015, EN61000-3-2:2014, EN61000-3-2:2013, EN55024 :2010/A1:2015
Safety standard(LVD)	EN 62321:2009
Certification	CE, EMC

Dimension

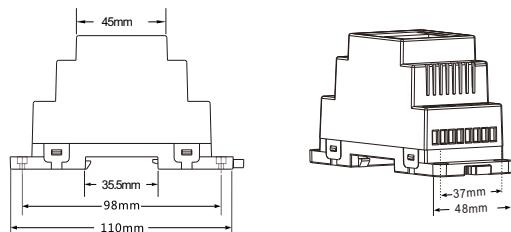

Wiring diagram

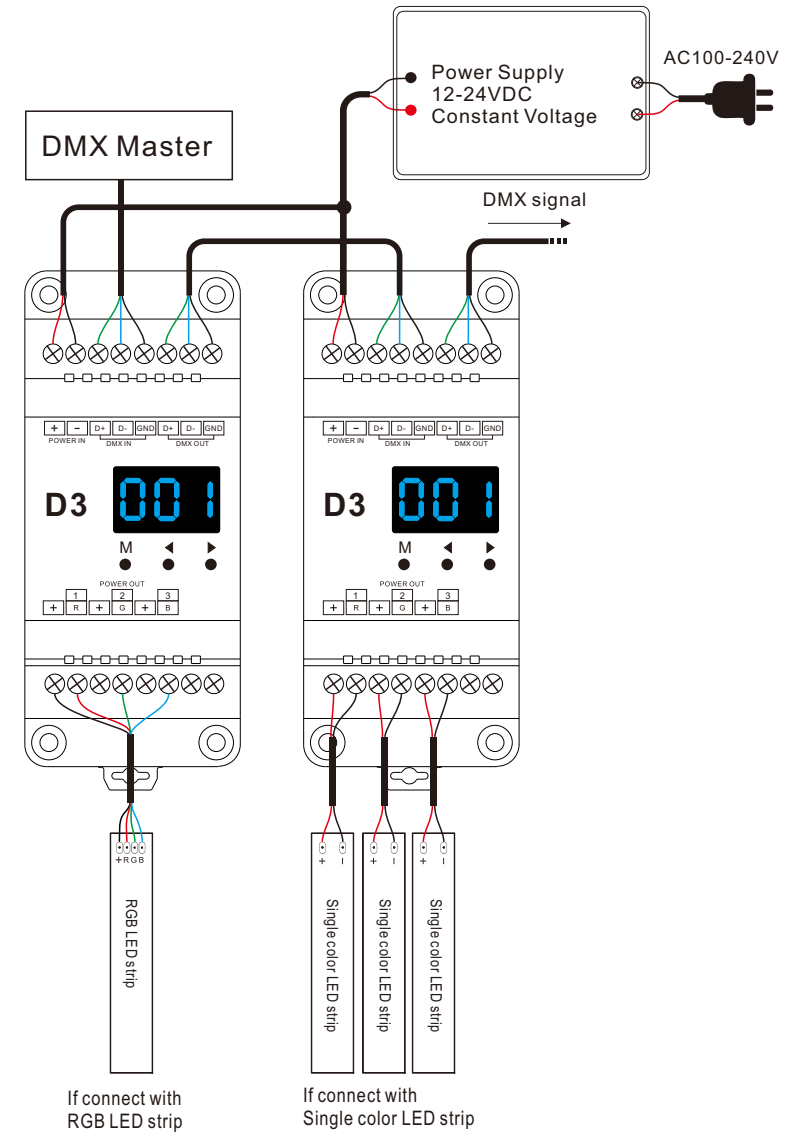

Operation

System parameter setting

- Long press M and ◀ key for 2s, prepare for setup system parameter: output PWM frequency, output brightness curve, automatic blank screen. short press M key to switch three item.
- Output PWM frequency: short press ◀ or ▶ key to switch 500Hz("F-L") or 2KHz("F-H").
- Output brightness curve: short press ◀ or ▶ key to switch linear curve("C-L") or logarithmic curve("C-E").
- Automatic blank screen: short press ◀ or ▶ key to switch enable ("bon") or disable("boF") automatic blank screen.
- Long press M key for 2s or timeout 10s, quit system parameter setting.

DMX mode

- Short press M key, when display 001~999, enter DMX mode.
- Press ◀ or ▶ key to change DMX decode address(001~999), long press for fast adjustment.
- If there is a DMX signal input, will enter DMX mode automatically.



DMX mode
(001~999)

Stand-alone RGB mode

- Short press M key, when display P01~P30, enter stand-alone RGB mode.
 - Press ◀ or ▶ key to change dynamic mode number(P01~P30).
 - Each mode can adjust speed and brightness.
- Long press M key for 2s, prepare for setup mode speed and brightness, Short press M key to switch two item.
- Press ◀ or ▶ key to setup value of each item.
- Mode speed : 1-10 level speed(S-1, S-9, S-F).
- Mode brightness: 1-10 level brightness(b-1, b-9, b-F).
- Long press M key for 2s, or timeout 10s, quit setting.
- Enter stand-alone RGB mode only when DMX signal is disconnected or lost.



Stand-alone RGB mode
(P01~P30)



Speed
(8 level)



Brightness
(10 level, 100%)

RGB change mode list

No.	Name	No.	Name	No.	Name
P01	Static red	P11	Green strobe	P21	Red yellow smooth
P02	Static green	P12	Blue strobe	P22	Green cyan smooth
P03	Static blue	P13	White strobe	P23	Blue purple smooth
P04	Static yellow	P14	RGB strobe	P24	Blue white smooth
P05	Static cyan	P15	7 color strobe	P25	RGB+W smooth
P06	Static purple	P16	Red fade in and out	P26	RGBW smooth
P07	Static white	P17	Green fade in and out	P27	RGBY smooth
P08	RGB jump	P18	Blue fade in and out	P28	Yellow cyan purple smooth
P09	7 color jump	P19	White fade in and out	P29	RGB smooth
P10	Red strobe	P20	RGBW fade in and out	P30	6 color smooth

Stand-alone dimmer mode

- Short press M key, when display L-1~L-8, enter stand-alone dimmer mode.
- Press ◀ or ▶ key to change dimmer mode number(L-1~L-8).
- Each dimmer mode can adjust each channel brightness independently. Long press M key for 2s, prepare for setup three channel brightness. Short press M key to switch three channel(100~1FF, 200~2FF, 300~3FF).
- Press ◀ or ▶ key to setup brightness value of each channel. Long press M key for 2s, or timeout 10s, quit setting.
- Enter stand-alone dimmer mode only when DMX signal is disconnected or lost.



Stand-alone dimmer mode
(L-1~L-8)

Restore factory default parameter

- Long press ◀ and ▶ key for 2s, restore factory default parameter, display "RES".
- Factory default parameter: DMX decode mode, DMX first address is 1, high PWM frequency output, logarithmic brightness curve, RGB mode number is 1, dimmer mode number is 1, disable automatic blank screen.

Malfunctions analysis & troubleshooting

Malfunctions	Causes	Troubleshooting
No light	1. No power. 2. Wrong connection or insecure.	1. Check the power. 2. Check the connection.
Wrong color	1. Wrong connection of R/G/B wires. 2. DMX decode address error.	1.Reconnect R/G/B wires. 2. Set correct decode address.
Uneven intensity between front and rear,with voltage drop	1. Output cable is too long. 2. Wire diameter is too small. 3. Overload beyond power supply capability. 4. Overload beyond controller capability.	1. Reduce cable or loop supply. 2. Change wider wire. 3. Replace higher power supply. 4. Add power repeater.

Safety information

1. The product shall be installed and serviced by a qualified person.
2. The product is non-waterproof. Please avoid the sun and rain.
3. Good heat dissipation will prolong the working life of the controller. Please ensure good ventilation.
4. Please check if the output voltage of any power supplies used comply with the working voltage of the product.
5. Ensure all wire connections and polarities are correct and secure before applying power to avoid any damages to the LED lights.
6. If a fault occurs please return the product to your supplier. Do not attempt to fix this product by yourself.