

3 Channel High Voltage LED Strip DMX512 & RDM Decoder

Model No.: S3-DX

RDM/Stand-alone function/Four PWM frequency/Linear or logarithmic dimming/Numeric display

Features

- Comply with the DMX512 standard protocols.
- Digital numeric display, set DMX decode start address by buttons.
- RDM function can realize intercommunication between DMX master and decoder. For example, DMX decoder address can be set by DMX master console.
- 1/3 DMX channel output selectable.
- PWM frequency 1000/2000/4000/8000Hz selectable.
- Logarithmic or linear dimming curve selectable.
- Stand-alone RGB mode selectable, which be controlled by buttons with built-in programs, instead of DMX signal.
- Match with RF 2.4G single zone or multiple zone RGB remote control optional.
- Green terminal, XLR3 and RJ45 port DMX signal input.



CE RoHS emc LVD

Technical Parameters

Input and Output		Safety and EMC		Environment	
Input voltage	110-240VAC	EMC standard (EMC)	ETSI EN 301 489-1 V2.2.3	Operation temperature	Ta: -30°C ~ +55°C
Input current	4.6A		ETSI EN 301 489-17 V3.2.4	Case temperature (Max.)	Ta: +85°C
Output voltage	3 x (110-240)VDC	Safety standard(LVD)	EN 62368-1:2020+A11:2020	IP rating	IP20
Output current	3CH, 1.5A/CH	Radio Equipment	ETSI EN 300 328 V2.2.2	Package	
Output power	3 x (165-360)W	Certification	CE, EMC, RED	Size	117.5x W80 x H45mm
		Warranty	5 years	Gross weight	0.470kg

Mechanical Structures and Installations

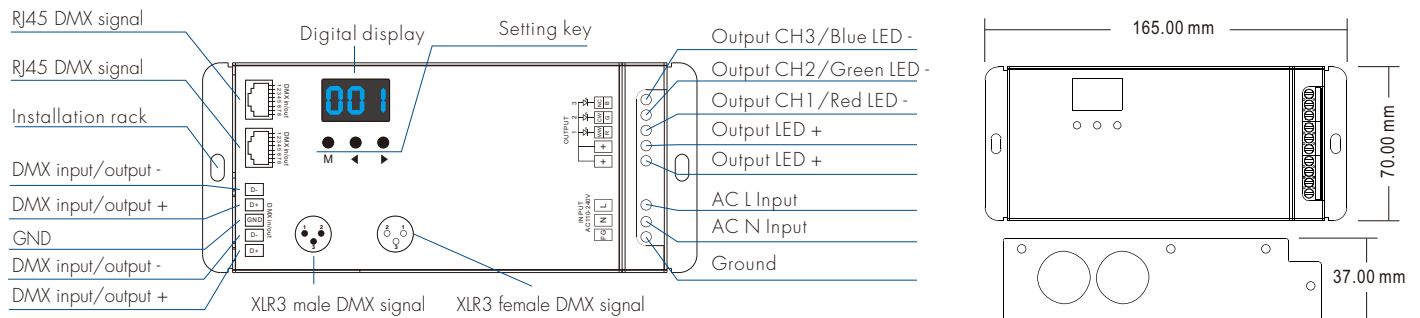

Wiring Diagram

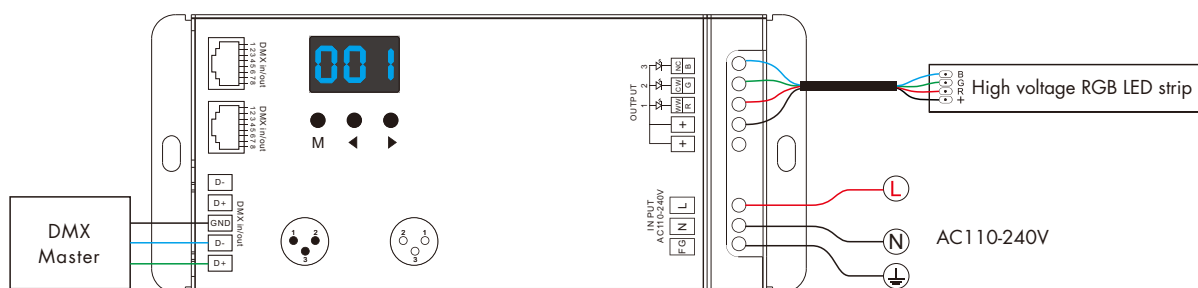

Caution:

This controller apply for high voltage LED strip, please carefully ensure all wire connections and polarities are correct and secure before applying power, otherwise this controller or high voltage LED strip will be damaged.

Operation

System parameter setting

- Long press M and ◀ key in the same time for 2s, prepare for setup system parameter: decode mode, output PWM frequency, output brightness curve, default output level, automatic blank screen. short press M key to switch five item.
- Decode mode: short press ◀ or ▶ key to switch 1/3 channel decode mode("d-1" or "d-3").
When set as 1 channel decode, the decoder occupy only 1 DMX address, and three channel output the same brightness of this DMX address.
- Output PWM frequency: short press ◀ or ▶ key to switch 1000Hz("F10"), 2000Hz("F20"), 4000Hz("F40") or 8000Hz("F80").
Higher PWM frequency, will cause lower output current, but more suitable for camera(No flickers for video).
- Output brightness curve: short press ◀ or ▶ key to switch linear curve("C-L") or logarithmic curve("C-E").
- Default output level: press ◀ or ▶ key to change default 0-100% level ("d00" to "dFF") when no DMX input signal.
- Automatic blank screen: short press ◀ or ▶ key to switch enable ("bon") or disable("boF") automatic blank screen.
- Long press M key for 2s or timeout 10s, quit system parameter setting.

DMX mode

- Short press M key, when display 001~512, enter DMX mode.
- Press ◀ or ▶ key to change DMX decode start address(001~512), long press for fast adjustment.
- If there is a DMX signal input, will enter DMX mode automatically.
- DMX Dimming: Each S3-DX DMX decoder occupy 3 DMX address when connecting the DMX console.
For example, the defaulted start address is 1,
their corresponding relationship in the form:

DMX mode
(001~512)

DMX Console	DMX Decoder Output
CH1 0-255	CH1 PWM 0-100% (LED R)
CH2 0-255	CH2 PWM 0-100% (LED G)
CH3 0-255	CH3 PWM 0-100% (LED B)

Stand-alone RGB mode

- Enter stand-alone RGB mode only when DMX signal is disconnected or lost.
- Short press M key, when display P-H or P01~P10, enter stand-alone RGB mode.
- Press ◀ or ▶ key to change static adjustable mode(P-H) and dynamic mode(P01~P10).
- When run static adjustable mode, can adjust three channel brightness respectively.
Long press M key for 2s, prepare for setup three channel brightness.
Short press M key switch three channel dimming(100~1FF, 200~2FF, 300~3FF),
press ◀ or ▶ key adjust each channel brightness.
- When run 30 dynamic mode, can adjust each mode speed and brightness.
Long press M key for 2s, prepare for setup speed or brightness.
Short press M key to switch two item.
Press ◀ or ▶ key to setup value of each item.
Mode speed: 1-10 level speed(S-1, S-9, S-F).
Mode brightness: 1-10 level brightness(b-1, b-9, b-F).
Long press M key for 2s, or timeout 10s, quit setting.

Stand-alone RGB mode
(P01~P10)

Speed
(8 level)

Brightness
(10 level, 100%)

RGB change mode list

No.	Name	No.	Name
P01	RGB jump	P06	RGB fade in and out
P02	RGB smooth	P07	Red fade in and out
P03	ó color jump	P08	Green fade in and out
P04	ó color smooth	P09	Blue fade in and out
P05	Yellow cyan purple smooth	P10	White fade in and out

RF mode

- Match: Long press M and ▶ key for 2s, display "RLS",
within 5s, press on/off key of the RF remote, display "RLO", match is successful,
then use the RF remote to change mode number, adjust speed or brightness.
- Delete: Long press M and ▶ key for 5s, until display "RLE", delete all matched RF remote.

Restore factory default parameter

- Long press ◀ and ▶ key for 2s, restore factory default parameter, display "RES".
- Factory default parameter: DMX decode mode, DMX decode start address is 1, 3 channel decode, 2000Hz PWM frequency output, logarithmic brightness curve, output 100% level when no DMX input, RGB mode number is 1, dimmer mode number is 1, disable automatic blank screen.