

CXR-21A-2(WT), CXR-28A-2(WT)

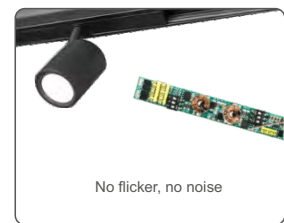

WiFi & RF 2CH Constant Current LED Driver

- Special for magnetic & linear lamp.
- No input polarity.
- DC to DC constant current output, multiple output current settings.
- Tuya smart APP cloud control, support on/off, color temperature and brightness adjust, delay turn on/off light, timer run, scene edit and music play function.
- Voice control, support for Amazon Alexa, Google Assistant, Tmall Genie and Xiaodu voice assistant.
- Match with RF 2.4G remote control optional.
- Suitable for STUCCHI standard housings, magnetic installation.
- Smooth dimming without flicker, quiet without noise.
- Short circuit, overload, no-load and anti-reverse protection.
- 5-year warranty.



Technical Parameters

Model		CXR-21A-2(WT)	CXR-28A-2(WT)
Output	Output Voltage	10~42VDC	
	Output Current	2x(150-500)mA	2x(350-700)mA
	Output Power	1.5W- 21W	3.5W-29.4W
	Current Accuracy	± 5%	
	Dimming Range	0~ 100%, 1024 levels dimming	
	Channel num	2	
Input	Dimming Interface	WiFi + RF 2.4G	
	Input Voltage	48VDC± 5% (No polarity)	
	Input Current	Max.0.47A	Max.0.65A
	Efficiency (Typ)	93%	95%
	Standby Power	<0.5W	
Environment	Woking Temperature	-20~50°C	
	Storage Temp	-40~80°C	
	Working Humidity	20~95%RH, non-condensing	
Protection	Overload	When load voltage exceed its range, the current declines, auto recovers when the load is reduced.	
	Short Circuit	Shut down automatically if short circuit occurs, auto recovers.	
	Reverse connection	Prevent driver and load damage	
Other	Size	L117xW13.5xH12.2mm	
	Weight	13.1g±2g	

LED Current Selection

Note: Please select the correct current through the DIP switch on the PCB board when the power is off.



DIP Switch											
CXR-21A-2(WT)	Output Current	150mA	200mA	250mA	300mA	350mA	400mA	450mA	500mA		ON OFF
	Output Voltage	10-42V	10-42V	10-42V	10-42V	10-42V	10-42V	10-42V	10-42V		
	Output Power	1.5-6.3W	2-8.4W	2.5-10.5W	3-12.6W	3.5-14.7W	4-16.8W	4.5-18.9W	5-21W		

DIP Switch											
CXR-28A-2(WT)	Output Current	350mA	400mA	450mA	500mA	550mA	600mA	650mA	700mA		ON OFF
	Output Voltage	10-42V	10-42V	10-42V	10-42V	10-42V	10-42V	10-42V	10-42V		
	Output Power	3.5-14.7W	4-16.8W	4.5-18.9W	5-21W	5.5-23.1W	6-25.2W	6.5-27.3W	7-29.4W		

Mechanical Structures and Installations

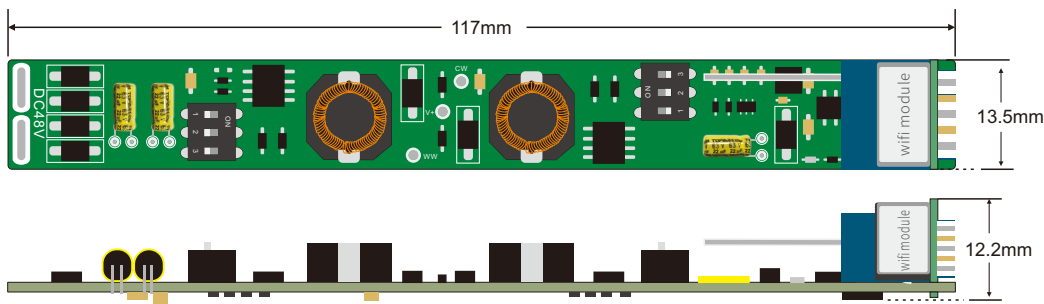

Wiring Diagram

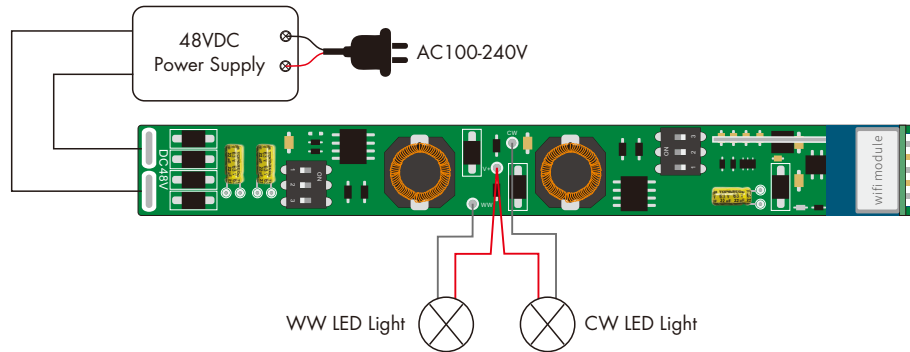

System wiring

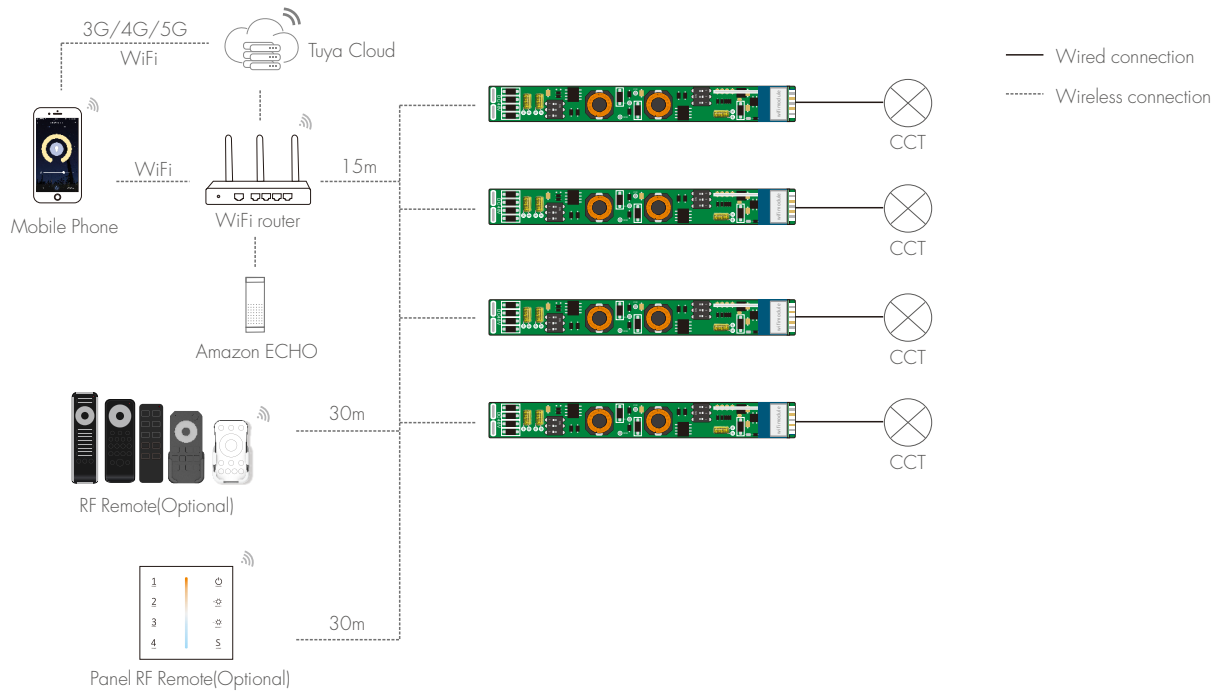

Note:

1. The above distance is measured in spacious (no obstacle) environment, please refer to the actual test distance before installation.
2. Please check if the WiFi router net in 2.4G band, the 5G band is not available, and do not hide your router network.
3. Please keep the distance between LED driver and router close, and check the WiFi signals.

Tuya Smart APP network connection

Repeat power on and off for 5 consecutive times, clear previous network connection, enter Smart config mode, the output LED will flash 10 times.

If Tuya smart APP network connection succeed, the RUN LED indicator will stop flash, and in Tuya smart APP, you can find CCT device.

Tuya Smart APP interface

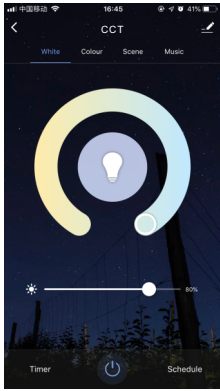

White interface

Touch color wheel to adjust color temperature.
Touch brightness slide to adjust brightness.

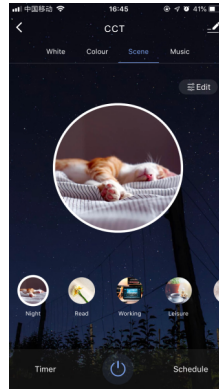

Scene interface

The 1-4 scene is static color.
The inner color of these scene can be editable.

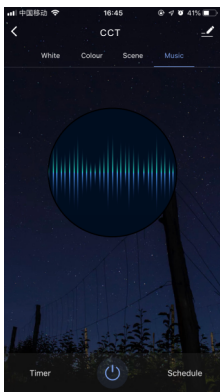

Music, Timer, Schedule

The music play can use smart phone music player or micro-phone as music signal input.
The Timer key can turn on or turn off light in the next 24 hours.
The Schedule key can add multiple timers to turn on or turn off light according to different time periods.

Match Remote Control

Match:

Switch off the power of the LED driver, then switch on power, repeat again.
Immediately short press on/off key (single zone remote) or zone key (multiple zone remote) 3 times on the remote.
The light blinks 3 times means match is successful.

Delete:

Switch off the power of the LED driver, then switch on power, repeat again.
Immediately short press on/off key (single zone remote) or zone key (multiple zone remote) 5 times on the remote.
The light blinks 5 times means all matched remotes were deleted.

Dimming Curve

