

# E1-W(D),E1-W(L)

## Paste Anywhere Hand Sweep Sensor Switch

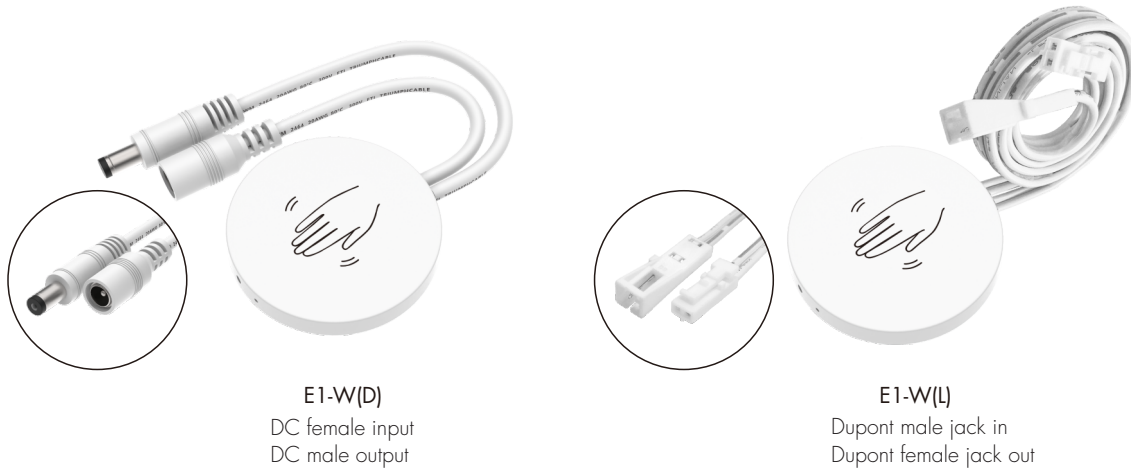

E1-W(D)

DC female input  
DC male output

E1-W(L)

Dupont male jack in  
Dupont female jack out

CE RoHS

### Feature

- Paste anywhere hand sweep sensor switch, 5-24VDC power supply, output connected to low voltage LED strip.
- Can detect hand waving motions through non-metallic materials such as wood, acrylic, plastic and glass.
- Hand sweep once the light fade on, sweep again the light fade off.
- Detection distance  $\leq 5\text{cm}$ .
- 1s light on fade, 2s light off fade.
- Logarithmic dimming curve.
- Hand stay moments can be set dimmable or non-dimmable.
- 3 levels of output PWM frequency can be set (500Hz/2KHz(default)/4KHz).
- Ultra-thin design, no need to cut hole, random paste installation, can be hidden.
- Apply to light illumination of cabinets, closets, wine cabinets and so on.

### Dimension

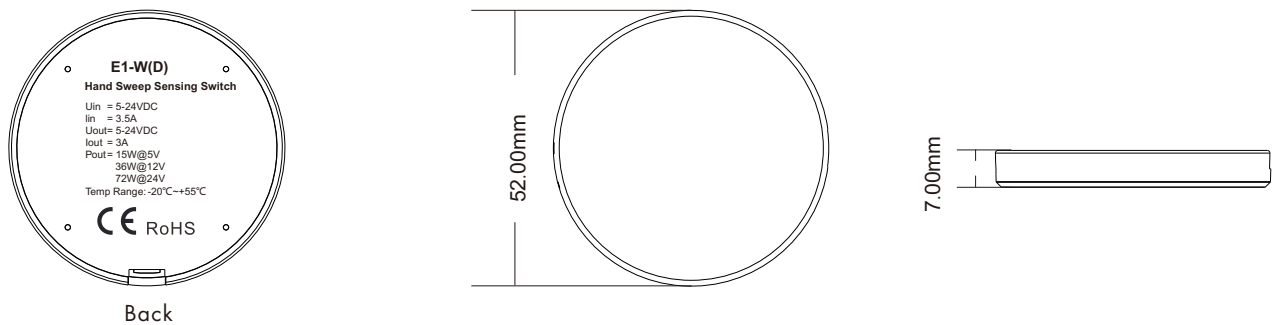

### Technical Parameters

Input and Output		Environment and Protection		Safety and EMC	
Input voltage	5-24VDC	Operation temperature	Ta: -20°C ~ +55°C	Safety standard	EN 61347-1/-2 EN 62493
Output voltage	5-24VDC	Protection	Reverse polarity	EMC standard	EN IEC 55015/EN IEC 61547
Output current	3A	Package		Certification	CE RoHS
Output power	15-72W	Size	90x130mm	Warranty	5 years
PWM Frequency	500Hz/2KHz(default)/4KHz	Gross weight	0.036kg		

### Wiring Diagram

- E1-W(D)

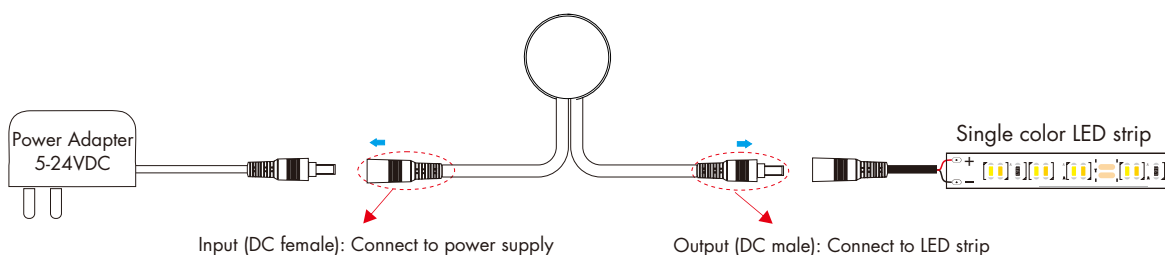

● E1-W(L)

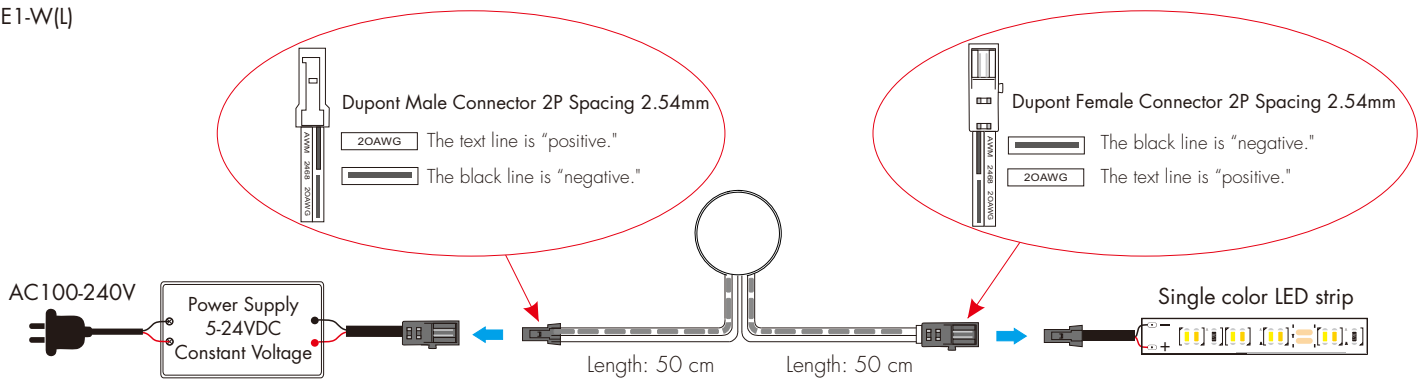

### Sensor Switch Function

**Hand sweep switch:**

Hand sweep once the light fade on, sweep again the light fade off.  
 When the hand stays within the detection distance for 2-7s, adjust the brightness of the light (adjustment range: 5-100%).  
 The brightness changes in the opposite direction when the hand moves away and stays again.  
 When the light is on, the indicator is brighter; when the light is off, the indicator is dimmer;  
 the indicator keeps blinking during brightness adjustment.

Factory default with dimming function, PWM frequency 2KHz.  
 Please set whether dimmable or not and PWM frequency according to the actual installation requirements  
 by short press or long press the set key with equipped pins.

**Set whether dimmable or not:**

Short press the set key to set whether dimmable or not.  
 When set to dimmable mode, the indicator blinks 1 time;  
 When set to non-dimmable mode, the indicator blinks 2 times.  
 Note: When the sensor switch is powered up, the LED indicator will blink  
 the corresponding number of times according to the current setting value.

**Set the PWM frequency:**

Long press the set key for 5-15s to set 3 kinds of PWM frequency in sequence.  
 Long press for 5s, the PWM frequency is set to 500Hz and the indicator blinks 1 time;  
 Long press for 10s, the PWM frequency is set to 2KHz and the indicator blinks 2 times;  
 Long press for 15s, the PWM frequency is set to 4KHz and the indicator blinks 3 times;  
 Note: When long pressed, the indicator light is off and will blink the corresponding number of times at the 5s, 10s, and 15s moments.

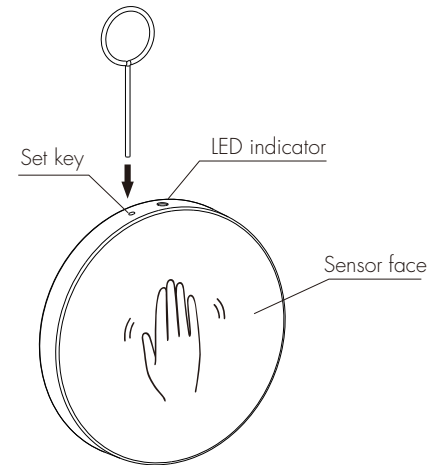

**Memory function:**

After power failure and turn on again, the device automatically restores the setting parameters before power failure.

### Sensor Switch Installation

**Open installation:**



The sensor head is stuck on the front side, please ensure that the sensor face is directly in front of the sensor area.

**Concealed installation:**

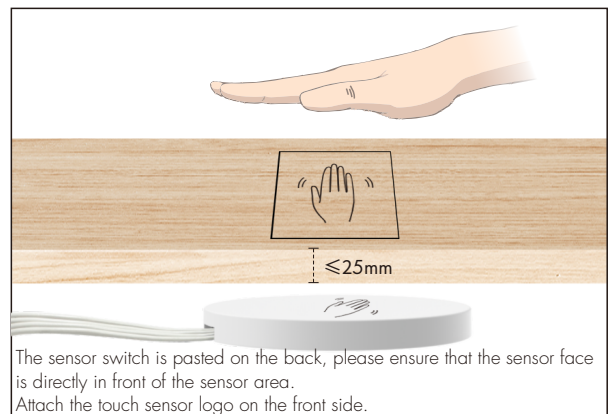

The sensor switch is pasted on the back, please ensure that the sensor face is directly in front of the sensor area.  
 Attach the touch sensor logo on the front side.

**Installation Precautions:**

1. Please use 3M adhesive to install the sensor switch anywhere or on the back of non-metallic materials such as wood, plastic, glass, acrylic, etc.
2. The sensor switch is not affected by ambient temperature, humidity, light, etc., and has strong anti-interference capability.
3. When installing, place the sensing side up.
4. Concealed detection thickness  $\leq 25\text{mm}$ .

### Sensor Switch Application



Wine cabinet application



Closet application



Cabinet application



Showcase application