

0/1-10V Bluetooth + RF + Push Dimmer

- Bluetooth + RF + AC push 0/1-10V dimmer, 1 channel output.
- Output 1 channel 0/1-10V signal, connect with 0/1-10V dimmable driver.
- Tuya smart APP cloud control, support on/off, brightness adjust, delay turn on/off light, timer run, scene function.
- Voice control, support for Amazon Alexa, Google Assistant, Tmall Genie and Xiaodu voice assistant.
- 0-10V or 1-10V output selectable by DIP switch.
- 256 levels 0-100% dimming smoothly without any flash.
- Compatibility with RF 2.4G single zone or multiple zone dimming remote control.
- Each L1(WB) controller can also work as Bluetooth-RF converter, then use Tuya smart APP to control one or more RF dimming LED controller or driver synchronously.
- Connect with external push switch to achieve on/off and 0-100% dimming function.
- Light on/off fade time 3s selectable.
- Easy to be placed in standard wall junction box behind a push switch.



CE RoHS RED

Technical Parameters

Input and Output		Environment		Safety and EMC	
Input voltage	AC100-240V	Operation temperature	Ta: -30 °C ~ +55 °C	EMC standard	EN 62479:2010 ETSI EN 301 489-1 V2.2.3 ETSI EN 301 489-17 V3.2.4
Output signal	0/1-10V (20mA)	Case temperature (Max.)	Tc: +65 °C	Safety standard	EN 61347-1:2015+A1:2021 EN 61347-2-13:2014+A1:2017
Dimming data		IP rating		Radio Equipment	ETSI EN 300 328 V2.2.2
Input signal	Bluetooth + RF + Push Dim	IP rating	IP20	Certification	CE RED
RF control distance	30m(Barrier-free space)	Package		Warranty	5 years
Dimming level	256 levels	Size	L60 x W60 x H40mm		
Dimming range	0-100%	Gross weight	0.060kg		

Mechanical Structures and Installations

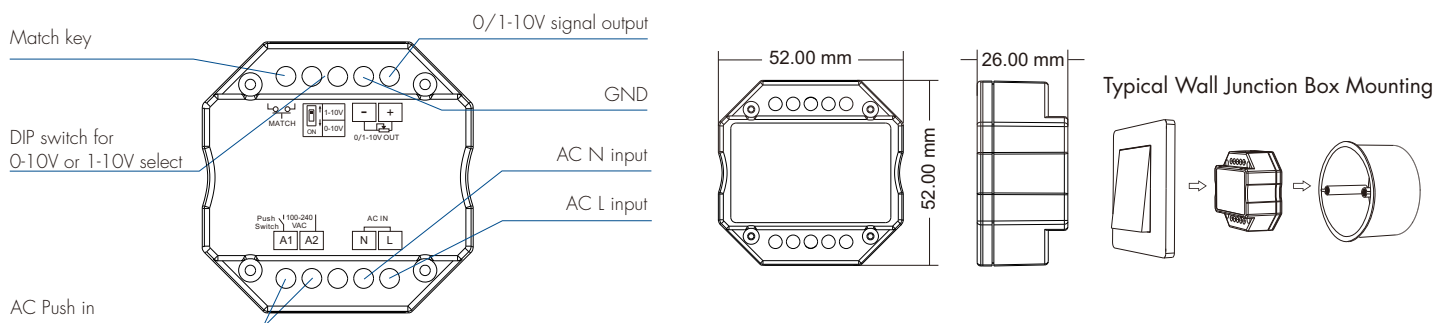

System Wiring

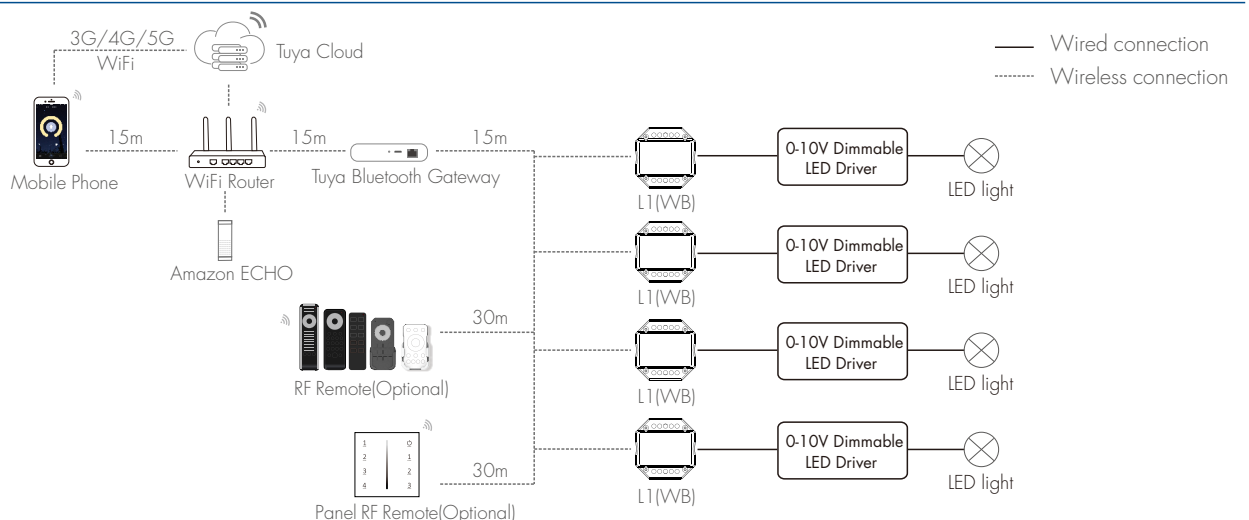

Note:

1. The above distance is measured in spacious (no obstacle) environment, please refer to the actual test distance before installation.
2. Users must use the Tuya Bluetooth gateway to realize remote control and voice control.

Wiring Diagram

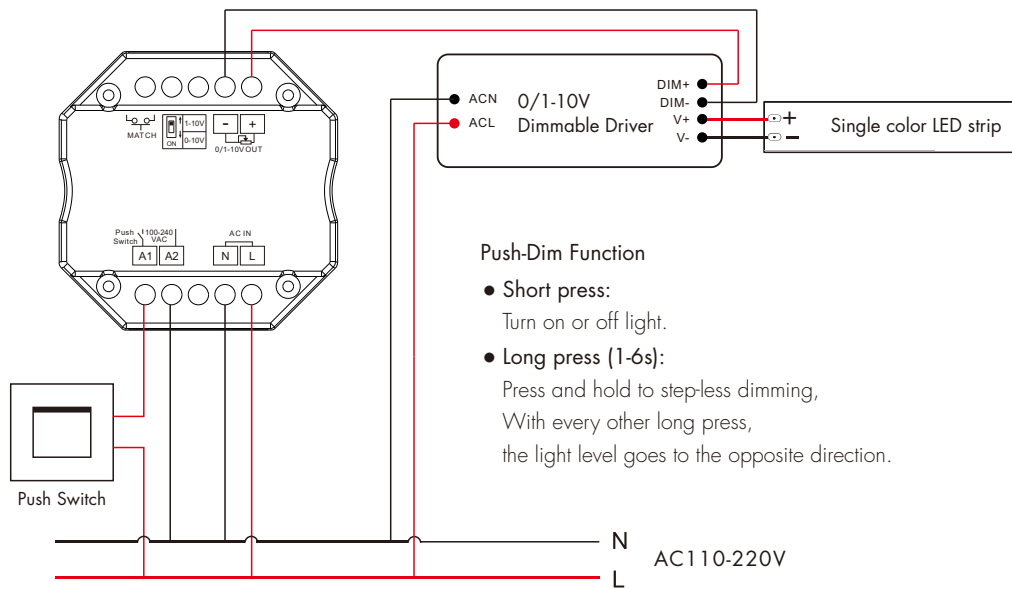

Note:

1. In order to ensure dimming consistency, we recommend the number of LED drivers connected to 0/1-10V dimmer does not exceed 50 pcs,
The maximum length of the wires from dimmer to LED driver should be no more than 50 meters
(use copper wire with a cross-sectional area of 0.75 m² for wiring).
2. Switch off the power, then switch on power, repeat again.
Immediately short press match key 3 times, the light on/off time will change between 3s and 0.5s.

Tuya Smart APP Network Connection and Operation

Press and hold Match/Set key for 5s,
or push twice Match/Set key fastly,
Clear previous network connection, enter config mode.
the blue LED indicator fast flash.

If Tuya smart APP network connection succeed,
the blue LED indicator will stop flash,
and in Tuya smart APP, you can find BT-DIM device.

Tuya smart APP interface operation:
Touch brightness slide to adjust brightness.

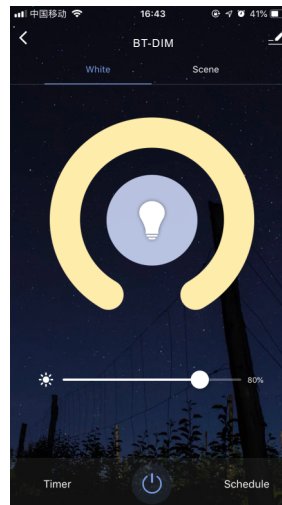

0-10V or 1-10V Dimming Setting

Select 0-10V dimmer or 1-10V dimmer according to Zigbee LED driver.

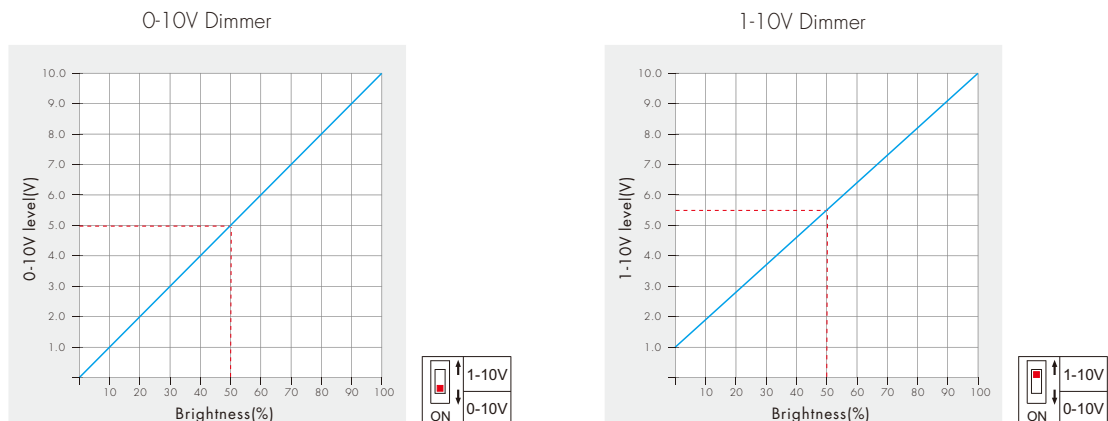

L1(WB) Match RF Remote Control (Optional)

End user can choose the suitable match/delete ways. Two options are offered for selection:

Use the L1(WB)'s Match key

Match:

Short press match key of L1(WB),
immediately press on/off key (single zone remote)
or zone key (multiple zone remote) on the remote.

Delete:

Press and hold match key of L1(WB) for 10s to delete all match,
The light blinks 5 times means all matched remotes were deleted.

Use Power Restart

Match:

Switch off the power of L1(WB), then switch on power, repeat again.
Immediately short press on/off key (single zone remote)
or zone key (multiple zone remote) 3 times on the remote.
The light blinks 3 times means match is successful.

Delete:

Switch off the power of L1(WB), then switch on power, repeat again.
Immediately short press on/off key (single zone remote)
or zone key (multiple zone remote) 5 times on the remote.
The light blinks 5 times means all matched remotes were deleted.

L1(WB) Work as Bluetooth-RF Converter to Match Other RF Dimming LED Controller or Driver

End user can choose the suitable match/delete ways. Two options are offered for selection:

Use the controller's Match key

Match:

Short press match key of the controller,
immediately press on/off key on the Tuya smart APP.
The LED indicator fast flash a few times means match is successful.

Delete:

Press and hold match key of the controller for 5s,
The LED indicator fast flash a few times means match was deleted.

Use Power Restart

Match:

Switch off the power of the controller, then switch on power, repeat again.
Immediately short press on/off key 3 times on the Tuya smart APP.
The light blinks 3 times means match is successful.

Delete:

Switch off the power of the controller, then switch on power, repeat again.
Immediately short press on/off key 5 times on the Tuya smart APP.
The light blinks 5 times means match was deleted.