

Zigbee 3.0 Constant Current LED Driver

- Tuya smart APP cloud control, support brightness adjust, delay turn on/off, timer run, scene edit, sleep wake-up and biorhythms function
- Philips HUE APP control by connect with Philips HUE bridge
- Voice control, support for Amazon Alexa, Google Assistant, Tmall Genie and Xiaodu voice assistant
- Can relay and route to each other, up to 15 hops
- Match with Zigbee 3.0 remote or scene panel control optional
- Reset key for clearing network connection
- Universal AC input / Full range, High PF, High efficiency, Flicker Free
- Standby power input<0.5W, meets the requirements of ERP certification
- Single channel constant current output, configurable current via DIP switch
- Over-load / Short circuit protection, recover automatically
- Class II design, SELV safety ultra-low voltage
- Suitable for indoor LED lighting application
- 5 Year, 50,000hr warranty

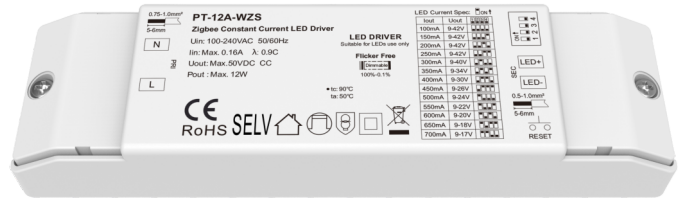

Applications

- Suitable for downlight, spotlight and decorative applications.
- Office / Commercial / Domestic Lighting, Hotels, Classrooms, Warehouse, Health care, Retail and Display.
- Use for retrofit upgrades & new luminaire designs.

Mechanical Structures and Installations

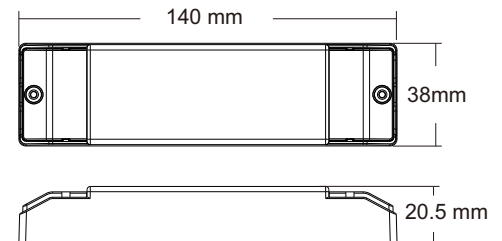
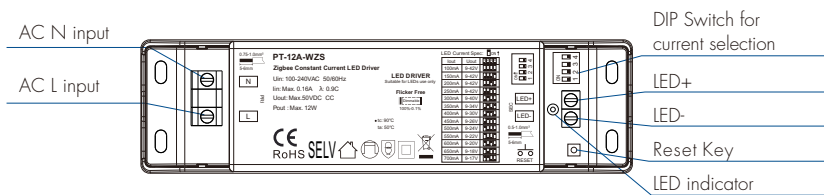

Technical Parameters

Output	Output Voltage	10~42VDC
	Max Output Voltage	50VDC
	Output Current	100-700mA
	Output Power	Max. 1.2W
	Dimming Range	0~100%, dimming depth:0.5%
	PWM Frequency	4KHz
	Current Accuracy	100mA gear $\pm 10\%$, the rest of the gear $\pm 5\%$
	Ripple & Noise	<5%(Maximum current non dimming state)
Input	Input Voltage Range	100~240VAC
	Frequency Range	50/60Hz
	Efficiency(TYP)	>80% (350mA at full load)
	Input Current	$\leq 0.15A/115VAC$, $\leq 0.08A/230VAC$
	Power Factor	>0.95/115VAC, >0.9/230VAC
	THD	<12% / 230VAC(at full load)
	Anti Surge	L/N: 1.5KV
	Inrush Current	Cold start8A, 135us duration(50% Ipeak) / 230VAC
	Leakage Current	< 0.6mA/230VAC
Standby Power/No Load Power	<0.5W (DIMMING OFF)	
Protection	Over Load Power	Current decrease or Hiccup, recovers automatically after fault condition is removed
	Short Circuit	Output short-circuit, shut down the output; after troubleshooting, restore the output
Environment	Working Temperature	-20°C~50°C
	T-case Max	90°C
	Working Humidity	20%~90%RH, non-condensing
	Storage Temp/Humidity	-40°C~80°C, 10%~95%RH
	Temperature Coefficient	$\pm 0.03\%/^{\circ}C$ (0-50%)
Safety&EMC	Vibration Resistance	10-500Hz, 2G, 6min/cycle, X,Y,Zaxes/2min
	Security Specifications	CE-IVD: EN 61347-2-13:2014/A1:2017, EN 61347-1:2015, EN 62493:2015
	Withstand Voltage	I/PO/P: 3750VAC
	Insulation Resistance	I/P/O/P: 100M/500VDC/25°C/70%RHQ
	EMC Emission	CE-EMC:EN55015,EN61000-3-2,EN61000-3-3
	EMC Immunity	CE-EMC: EN61000-4-2,3,4,5thunderbol1KV,6,11
	Certifications	CE

LED Current Selection: 

Output Voltage	9-42V	9-42V	9-42V	9-42V	9-40V	9-34V	9-30V	9-26V	9-24V	9-22V	9-20V	9-18V	9-17V	
Output Current	100mA	150mA	200mA	250mA	300mA	350mA	400mA	450mA	500mA	550mA	600mA	650mA	700mA	
Output Power	0.9-4.2W	1.35-6.3W	1.8-8.4W	2.25-10.5W	2.7-12W	3.15-11.9W	3.6-12W	4.05-11.7W	4.5-12W	4.95-12W	5.4-12W	5.85-11.7W	6.3-11.9W	

System Wiring

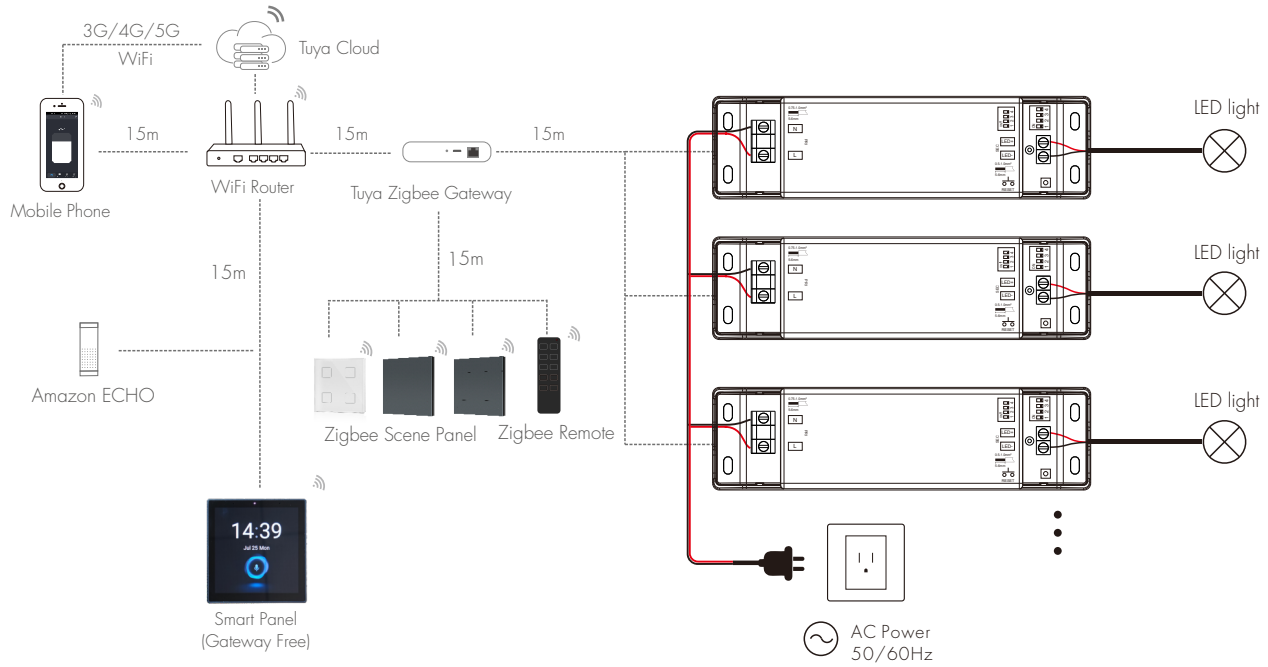

Note:

1. The above distance is measured in spacious (no obstacle) environment, Please refer to the actual test distance before installation.
2. Please check if the WiFi router net in 2.4G band, the 5G band is not available, and do not hide your router network.
3. Please keep the distance between LED driver and router close, and check the WiFi signals.
4. Users must use the Tuya ZigBee gateway to realize remote control and voice control (The smart panel integrate Zigbee gateway function).

App Operating Instructions

1. Network pairing

- Download the Tuya smart APP and register an account, search and add the Tuya Zigbee gateway device.
- Quickly press the "RESET" button five times or repeat power on and off five times to clear the previous network connection, enter pairing mode with the output light breathes blinking.
- Under the gateway, search and add new device. If the network connection is successful, you can find ZBS-DIM devices in Tuya smart APP.

2. Lighting control settings

After pairing the light device, click the device and change brightness by touch brightness slide.

In "Scene", there are 4 scene can be recalled or customized.

In "Setting", there are Plan, Schedule, Timer, Rhythms, Power-on behavior functions.

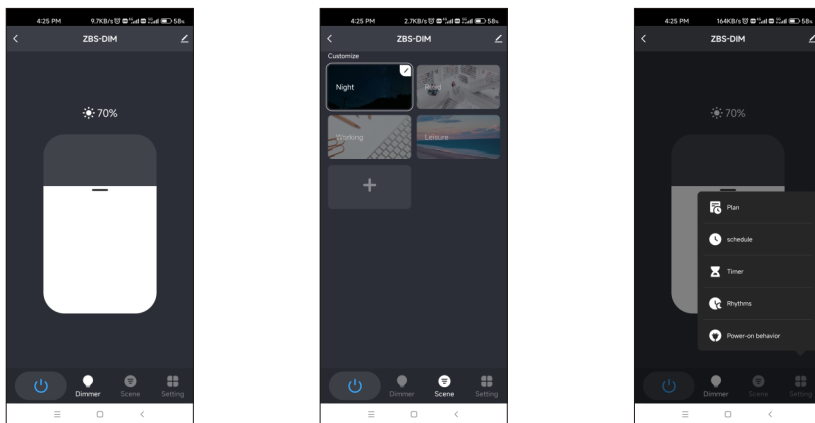

Installation Note

1. This product must be installed and adjusted by a qualified professional.
2. This product is non-waterproof, When installed outdoors, please ensure it is mounted in a water proof enclosure.
3. LED driver should keep a certain distance from the heating stuff(such as the luminaries radiator).
The installation interval between the product and the product is recommended to be 1.5cm, so as not to affect the service life due to poor heat dissipation of the product.
4. Before you power on the product, please make sure all the wiring is correct in case of incorrect connection that may cause a short circuit and damage the components, or trigger a accident.
5. If a fault occurs, please do not attempt to fix the product by yourself. If you have any questions, please contact us in time.